

PIN	DIM=A	DIM=B	DIM=C	DIM=D
70	39.40	36.50	34.50	35.60
69	38.90	36.00	34.00	35.10
68	38.40	35.50	33.50	34.60
67	37.90	35.00	33.00	34.10
66	37.40	34.50	32.50	33.60
65	36.90	34.00	32.00	33.10
64	36.40	33.50	31.50	32.60
63	35.90	33.00	31.00	32.10
62	35.40	32.50	30.50	31.60
61	34.90	32.00	30.00	31.10
60	34.40	31.50	29.50	30.60
59	33.90	31.00	29.00	30.10
58	33.40	30.50	28.50	29.60
57	32.90	30.00	28.00	29.10
56	32.40	29.50	27.50	28.60
55	31.90	29.00	27.00	28.10
54	31.40	28.50	26.50	27.60
53	30.90	28.00	26.00	27.10
52	30.40	27.50	25.50	26.60
51	29.90	27.00	25.00	26.10
50	29.40	26.50	24.50	25.60
49	28.90	26.00	24.00	25.10
48	28.40	25.50	23.50	24.60
47	27.90	25.00	23.00	24.10
46	27.40	24.50	22.50	23.60
45	26.90	24.00	22.00	23.10
44	26.40	23.50	21.50	22.60
43	25.90	23.00	21.00	22.10
42	25.40	22.50	20.50	21.60
41	24.90	22.00	20.00	21.10
40	24.40	21.50	19.50	20.60
39	23.90	21.00	19.00	20.10
38	23.40	20.50	18.50	19.60
37	22.90	20.00	18.00	19.10
36	22.40	19.50	17.50	18.60
35	21.90	19.00	17.00	18.10
34	21.40	18.50	16.50	17.60
33	20.90	18.00	16.00	17.10
32	20.40	17.50	15.50	16.60
31	19.90	17.00	15.00	16.10
30	19.40	16.50	14.50	15.60
29	18.90	16.00	14.00	15.10
28	18.40	15.50	13.50	14.60
27	17.90	15.00	13.00	14.10
26	17.40	14.50	12.50	13.60
25	16.90	14.00	12.00	13.10
24	16.40	13.50	11.50	12.60
23	15.90	13.00	11.00	12.10
22	15.40	12.50	10.50	11.60
21	14.90	12.00	10.00	11.10
20	14.40	11.50	9.50	10.60
19	13.90	11.00	9.00	10.10
18	13.40	10.50	8.50	9.60
17	12.90	10.00	8.00	9.10
16	12.40	9.50	7.50	8.60
15	11.90	9.00	7.00	8.10
14	11.40	8.50	6.50	7.60
13	10.90	8.00	6.00	7.10
12	10.40	7.50	5.50	6.60
11	9.90	7.00	5.00	6.10
10	9.40	6.50	4.50	5.60
9	8.90	6.00	4.00	5.10
8	8.40	5.50	3.50	4.60
7	7.90	5.00	3.00	4.10
6	7.40	4.50	2.50	3.60

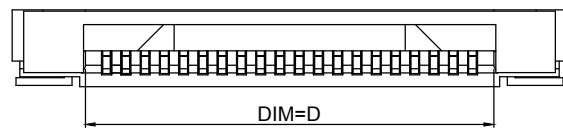

Electrical Characteristics:  
 Current rating: 0.5A AC/DC  
 Voltage rating: 50V AC/DC  
 Temperature range: -25°C~+85°C  
 Withstand Voltage: 200V AC/Minute  
 Contact Resistance: ≤ 20mΩ  
 Insulation resistance: ≥ 500MΩ  
 Relative Humidity: 93%+40°C  
 Material Description:  
 Terminal: Phosphor Bronze  
 Fitting Nail: Brass  
 Housing: Thermoplastic(UL94V-0)  
 Slider: Thermoplastic(UL94V-0)

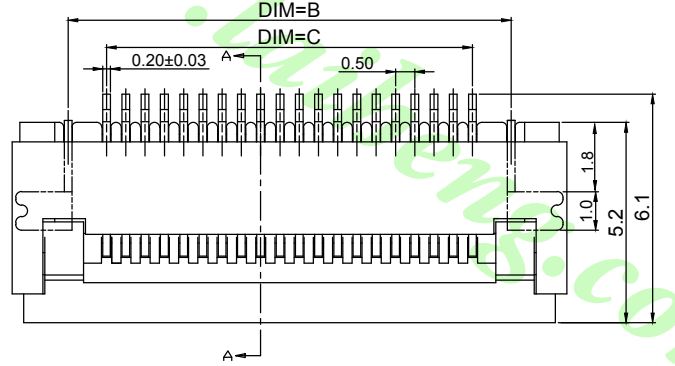
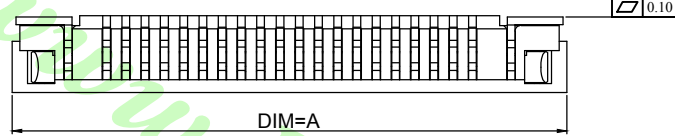
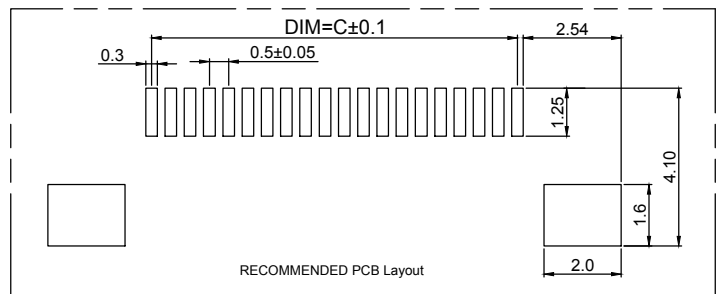
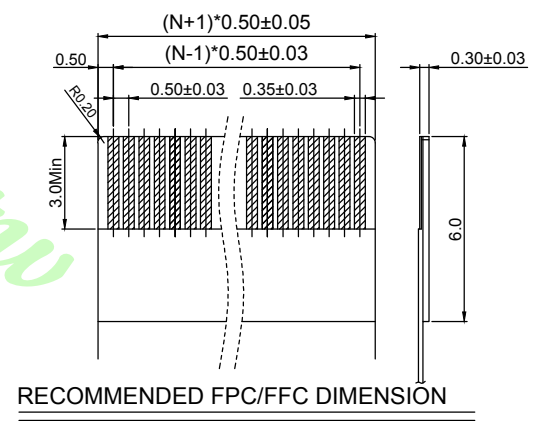
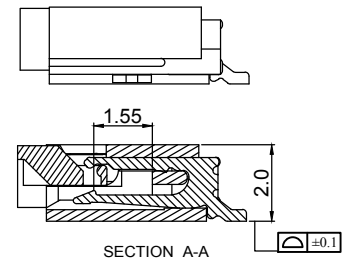

SERIES NO.	CONTACT TYPE	Pin no.	CONTACT PLATING	PACKAGE
LFPC-K855	B	XX	PT	2
FPC 0.5 pitch ZIF R/A SMT Easy on connector	B: Bottom contact	06~64	PT : PURE TIN G1 : Gold Flash	1:Tube 2:T&R

A0		NEW DRAWING	2018.06.18	公認/UNLESS OTHERWISE SPECIFIED TOLERANCES ARE .X ±0.35 .XX ±0.20 ANG. ±3°	單位/Unit mm 比例/Scale Free Size A4	品名/Title : FPC 0.5mm Pitch ZIF Easy on SMT R/A Bottom contact conn.	料號/Part No : LFPC-K855-B-XX-XX-X	圖號/Drawing No :
REV	概述/REVISION	日期/DATE						

**鍊亨電子有限公司**  
 LAI HENG TECHNOLOGY LTD.  
 TEL:(02) 8228-6487 FAX:(02) 8228-6486

核加/APPD. Joe 審核/CHKD. Joe 製圖/DR. Mandy 張數/Sheet 1 of 1

REV. A0