

P/N:LHDMI-19F1-08 & 18

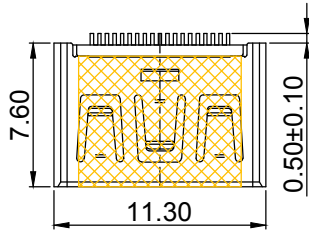

P/N:LHDMI-19F1-11

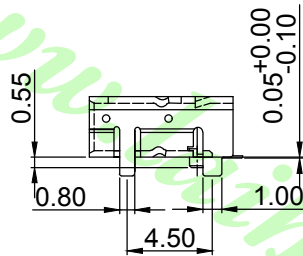
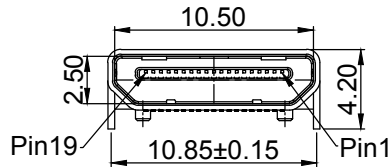
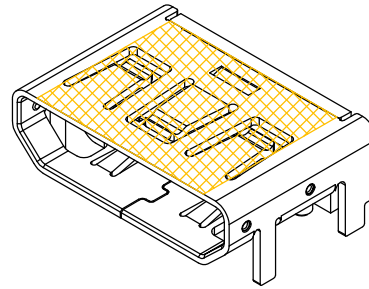
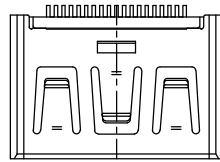

1. MATERIAL :
- 1-1. HOUSING : LCP UL94V-0 ; COLOR : BLACK.
 - 1-2. CONTACT : PHOSPHOR BRONZE.
 - 1-3. SHELL : BRASS.

2. FINISH :
- 2-1. CONTACT :
CONTACT AREA : SEE TABLE A;
SOLDER AREA : GOLD FLASH;
UNDER PLATE : NICKEL.
 - 2-2. SHELL : NICKEL PLATED 60u" OVER ALL.

3. ELECTRICAL SPECIFICATION :
- 3-1. Rated current : 0.5A.
 - 3-2. Voltage : 150V DC.

4. Environmental :
- 4-1. Operation Temperature : -20 ~ 85 .

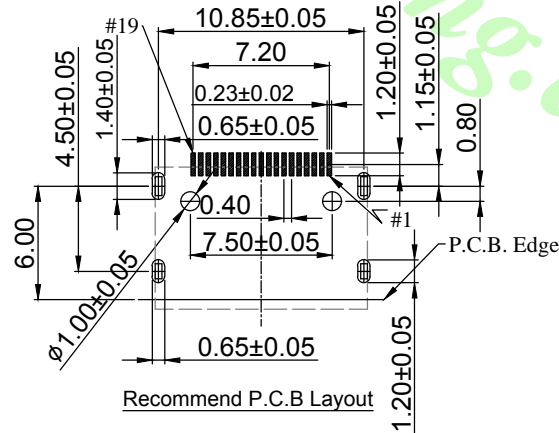
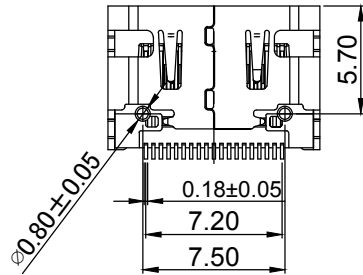

Recommend P.C.B Layout

TABLE A

LHDMI-19F1-18	金15u"
LHDMI-19F1-11 (無麥拉)	金15u"
LHDMI-19F1-08	金30u"
Part No.	PLATED

		公認/UNLESS OTHERWISE SPECIFIED TOLERANCES ARE		單位/Unit	品名/Title :	 鍊亨電子有限公司 LAI HENG TECHNOLOGY LTD. TEL:(02) 8228-6487 FAX:(02) 8228-6486	
				mm	HDMI 19P(F) C TYPE DIP		
A0	NEW DRAWING	2019.02.21	.X ±0.20	比例/Scale	料號/Part No :	圖號/Drawing No :	核加/APPD.
REV	概述/REVISION	日期/DATE	.XX ±0.10	Free	LHDMI-19F1-XX	QC2997	審核/CHKD.
			.XXX ±0.05	Size			製圖/DR.
			ANG. ±1°	A4			張數/Sheet
							1 of 2
							REV. A0

步驟一:

- 1.將成品一一放入包裝盤內,依同一方向置入.
- 2.包裝方式,如圖所示.
- 3.一個包裝盤800pcs.

步驟二:

- 1.一個紙箱可以裝10個包裝盤.
- 2.每盤800pcs,每箱8000pcs.
- 3.將包裝盤放入防水袋中,包裝完後再封箱.

步驟三:

- 1.用膠帶將紙箱封實.
- 2.將標籤貼於紙箱上.

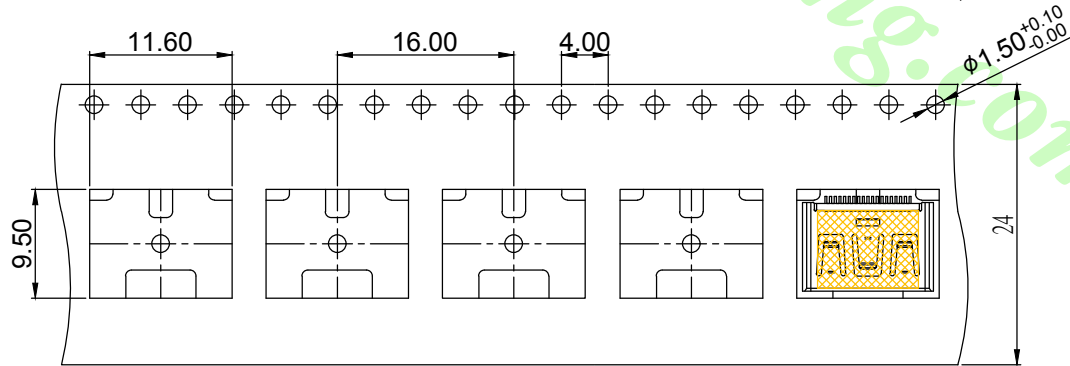
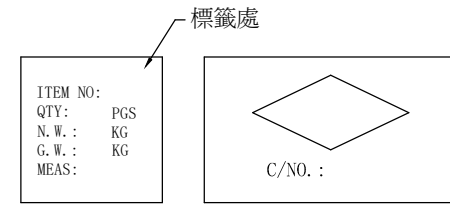
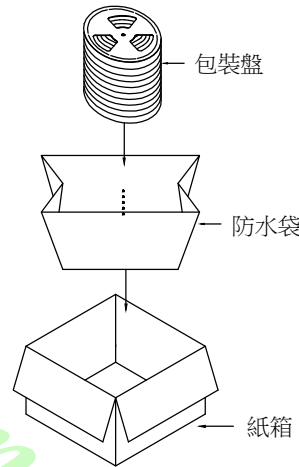
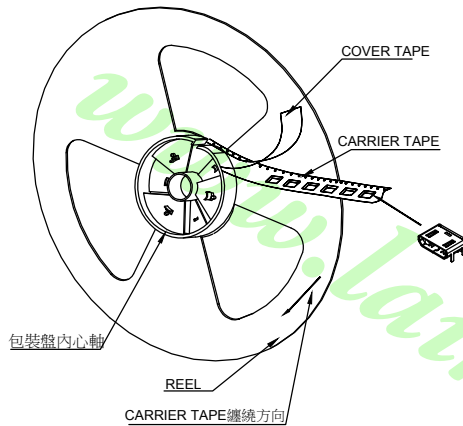
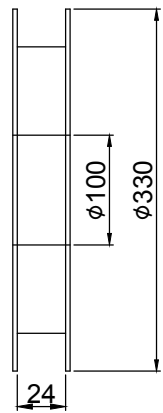

NOTE:

- 1.若有未裝滿之零數箱,必須以緩衝材塞滿.
- 2.在搬運過程中要輕拿輕放.
- 3.載運輸中不可堆放過多,不可有重壓現象.
- 4.在裝滿產品後,必須空留帶前和帶後20格,然後用紙膠布貼上.
- 5.上帶在貼下帶時必須平整,且黏貼處不要出現氣泡.

			公差/UNLESS OTHERWISE SPECIFIED TOLERANCES ARE	單位/Unit mm	品名/Title :	鍊亨電子有限公司 LAI HENG TECHNOLOGY LTD. TEL:(02) 8228-6487 FAX:(02) 8228-6486				
			.X ±0.20	比例/Scale	HDMI 19P(F) C TYPE DIP T&R Package (PM0074)					
A0	NEW DRAWING	2019.02.21	.XX ±0.10	Free	料號/Part No :	圖號/Drawing No : PK-1-HM-19F1-08				
REV	概述/REVISION	日期/DATE	.XXX ±0.05	Size A4	LHDMI-19F1-XX	核加/APPD.	審核/CHKD.	製圖/DR.	張數/Sheet	REV.
			ANG. ±1°			740	Joe	Mandy	2 of 2	A0